

- ※ Multifunction meter
Tachometer、Line speed meter & Duty meter
- ※ Pulses per revolution settable
- ※ Sampling time auto tuning
- ※ Decimal point settable
- ※ Limit of alarm settable
- ※ Transmitter of multifunction meter is optional

General data / 共同規格

Outline	外型	48x28	96x48			72x72	
Model	型號	SM-10	SM-20	SM-20S	SM-30	SM-30S	
Transmitter	再傳送	Non	Non	4~20mA	Non	4~20mA	
Alarm output	警報輸出	Relay	Relay	Non	Relay	Non	
Output control	輸出控制	Hi / Lo	Hi / Lo	Non	Hi / Lo	Non	
Digits	位數	4 digits					
Power supply	工作電壓	90 ~ 265 VAC 50/60 Hz					
Current consumption	耗電流	5VA max.					
DC output	直流輸出	12 V / 100 mA max.					
Input method	輸入方式	NPN					
Response time	應答時間	Ton = 0.1 ms ~ 99.9 ms settable					
Pulses per revolution (PPR)		1~999 PPR settable					
Diameter	轉軸直徑設定	1 ~ 999mm settable (Line speed meter available only)					
Memory method	記憶方式	EEPROM					
ESD strength	耐靜電	Over 8 KV					
Dielectric strength	電介強度	Over 2.5 KV / 1 min., Between power and each other terminal					
Isolation strength	絕緣強度	Over 100 MΩ / 500 VDC, Between power and each other terminal					
Operating Circums.	工作環寬	- 20 °C ~ + 80°C ; 35% ~ 85% RH					

Outline dimension / 外形尺寸圖

<p>SM-10 Fixed Hole : 45.0 x 23.0 Panel Thickness : 1.0 ~ 8.0 Unit : mm</p>	<p>SM-20 Fixed Hole : 45.0 x 91.0 Panel Thickness : 1.0 ~ 8.0 Unit : mm</p>	<p>SM-30 Fixed Hole : 68.0 x 68.0 Panel Thickness : 1.0 ~ 8.0 Unit : mm</p>
--	--	--

Tachometer & Line speed meter

SM-□□ Series

■ Data setting / 參數設定

Status / 狀態	Symb. / 顯示符號	Description / 說明
<div style="border: 1px solid black; padding: 5px;"> Running status 運轉狀態 Press SET Key 3 sec </div>	100.0	1> Running status / 運轉狀態
<div style="border: 1px solid black; padding: 5px;"> Setting of lock 鎖住設定 Press SET Key </div>	Lck.0	1> 「Lck=0」 : Unlock / 可設定 2> 「Lck=1」 : All lock / 鎖定
<div style="border: 1px solid black; padding: 5px;"> Setting of PPR 每轉信號數設定 Press SET Key </div>	PPR.1	1> 「PPR」 : Pulses per revolution 2> Range : 1 ~ 999
<div style="border: 1px solid black; padding: 5px;"> Setting of diameter 輪軸直徑設定 Press SET Key </div>	d.100	1> 「d..100」 : Diameter of roller=100 mm (Range=1~999mm) 2> Disappeared at tachometer mode
<div style="border: 1px solid black; padding: 5px;"> Setting of Limit 警報值設定 Press SET Key </div>	1000	1> Range : 0 ~ 9999 2> Range : 0 ~ 9999
<div style="border: 1px solid black; padding: 5px;"> Setting of alarm status 警報輸出狀態設定 Press SET Key </div>	C.0	1> 「C.0」 : PV> 「Limit value」 → Relay ON 2> 「C.1」 : PV< 「Limit value」 → Relay ON
<div style="border: 1px solid black; padding: 5px;"> Power on delay time 送電延遲時間 Press SET Key 3 sec </div>	t.0	1> 「t」 : 0 ~ 999s 2> Delay time of power on alarm output
<div style="border: 1px solid black; padding: 5px;"> Setting of distance 通過行程設定 Press SET Key </div>	L.000	1> Distance of measuring : Unit = 1 Meter 2> Passing time T (sec) = 「L」 / Line speed 3> 「L」 appeared at 「nod.5」 only

■ Function setting / 功能設定

Status / 狀態	Symb. / 顯示符號	Description / 說明
<div style="border: 1px solid black; padding: 5px;"> Running status 運轉狀態 Press DN Key 3 sec </div>	100.0	1> Running status / 運轉狀態 2> SM-10/SM-30 : ▼ key ; SM-20 : DN key
<div style="border: 1px solid black; padding: 5px;"> Selection of meter 轉速表或線速表選擇 Press SET Key </div>	nod.0	1> 「nod.0」 = RPM ; 2> 「nod.1」 = RPS 3> 「nod.2」 = RPH ; 4> 「nod.3」 = M / min. 5> 「nod.4」 = Yd/min ; 6> 「nod.5」 = T sec
<div style="border: 1px solid black; padding: 5px;"> Setting of response time 反應時間設定 Press SET Key </div>	r.00.1	1> Response time(r) : Response frequency = (500 / r) Hz 2> Range : 0.1 ~ 99.9 ms
<div style="border: 1px solid black; padding: 5px;"> Setting of decimal point 小數點選擇 Press SET Key </div>	dP.A	1> 「dP.A」 = Decimal point auto shift 2> 「dP.n」 = Without decimal point 3> 「dP.1」 = One decimal point

■ Data setting / 參數設定

Status / 狀態	Symb. / 顯示符號	Description / 說明
Running status 運轉狀態 Press SET Key 3 sec	100.0	1> Running status / 運轉狀態
Setting of lock 鎖住設定 Press SET Key	Lck.0	1> 「Lck = 0」 : Unlock / 可設定 2> 「Lck = 1」 : All lock / 鎖定
Setting of PPR 每轉信號數設定 Press SET Key	PPR1	1> 「PPR」 : Pulses per revolution 2> Range : 1 ~ 999
Setting of diameter 輪軸直徑設定 Press SET Key	d.100	1> Diameter of roller : 1 ~ 999 mm 2> Disappeared at tachometer mode
Limit of transmitter 傳送範圍設定 Press SET Key	1000	1> Angle of transmitter : 0 ~ 9999 「0 ~ 1000」 is transmitted to 「4 ~ 20 mA」 2> Range : 0 ~ 9999
Setting of distance 通過時間行程設定 Press SET Key 3 sec	L.00.0	1> Distance of measuring : Unit = m 2> Passing time T (sec) = 「L」 / Line speed 3> 「L」 appeared at 「nod.5」 only

■ Function setting / 功能設定

Status / 狀態	Symb. / 顯示符號	Description / 說明
Running status 運轉狀態 Press DN Key 3 sec	100.0	1> Running status / 運轉狀態
Selection of meter 轉速表或線速表選擇 Press SET Key	nod.0	1> 「nod.0」 = RPM ; 2> 「nod.1」 = RPS 3> 「nod.2」 = RPH ; 4> 「nod.3」 = M / min. 5> 「nod.4」 = Yd/min ; 6> 「nod.5」 = T sec
Setting of response time 反應時間設定 Press SET Key	r.00.1	1> Response time(r) : Response frequency = (500 / r) Hz 2> Range : 0.1 ~ 99.9 ms
Setting of decimal point 小數點選擇 Press SET Key	dP.A	1> 「dP.A」 = Decimal point auto shift 2> 「dP.n」 = Without decimal point 3> 「dP.1」 = One decimal point
Offset of 4 mA 4 mA偏差值設定 Press SET Key	□.000	1> Range : -99 ~ 999 2> Offset of transmitter (4 mA)
Offset of 20 mA 20 mA偏差值設定 Press SET Key	□.000	1> Range : -99 ~ 999 2> Offset of transmitter (20 mA)

■ Connection diagram / 接線圖

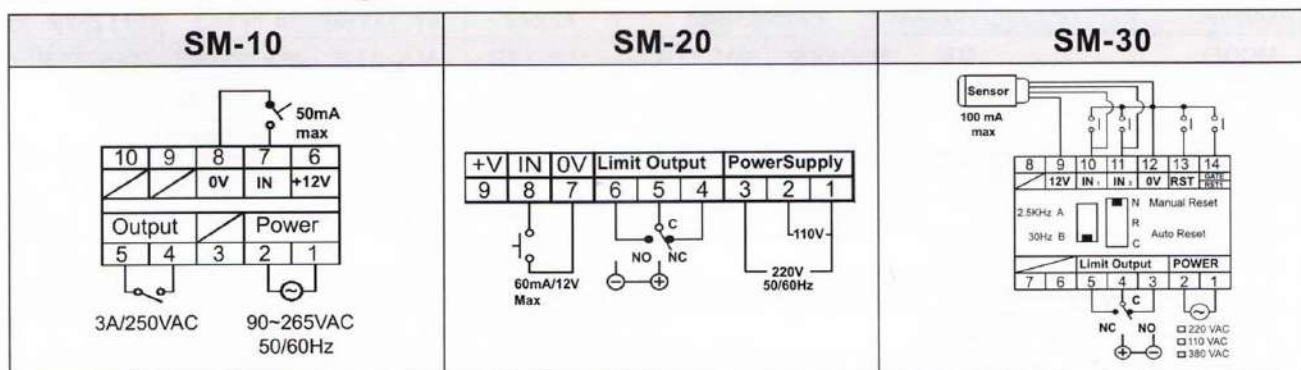

■ Selection of meter / 轉速表或線速表選擇

nod	Type of meter	Method of measuring
「0」	Tachometer (RPM)	「RPM」: Revolutions per minute 每分鐘幾轉
「1」	Tachometer (RPS)	「RPS」: Revolutions per second 每秒幾轉
「2」	Tachometer (RPH)	「RPH」: Revolutions per hour 每小時幾轉
「3」	Line speed meter (M/min.)	「M/min.」: Meter per minute.
「4」	Line speed meter (Yd/min.)	「Yd/min.」: Meter per minute.
「5」	Duty meter (SEC)	「SEC」: Time of duty

■ Alarm output

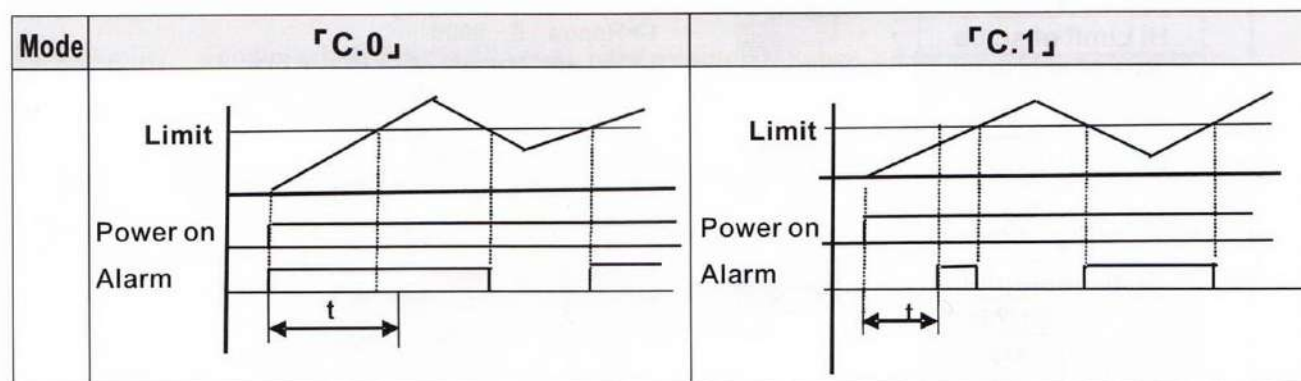

■ Duty meter : To measure the passing time (T) from "A" to B"

Passing time : 「T」 (sec)

$$「T」 \text{ (sec)} = 「L」 / \text{Line speed}$$

「d」 mm = Diameter of roller

「L」 m = Distance from "A" to B"

